

TOOL RACKS

BAHCO
DORTMUND



TOOL RACKS WS95

BAHCO

The tool rack of the series WS 95 allows numerous applications due to its modular system. Its construction allows better alignment of the tool during drilling, screwing or thread cutting and easy operation for the user.

- 2 column lengths (custom lengths available on request)
- No reverse rotation forces
- Smooth operation through recirculating ball bearings
- Large working area
- rotatable by 360 °
- adjustable tool arm
- extension length adjustable by adjusting rings

- Tool tension over prism support
- Quick tool change
- Supplied with spring balancer and spiral hose
- Optional accessories available
 - ✓ Extended tool arm
 - ✓ Large Prism recording („G“ version)
 - ✓ Lock against rotation
 - ✓ Second spring balancer, resp. other weight ranges

ABMESSUNGEN

Type	Working radius standard mm	Max. torque reaction Nm	Column lengths mm	Holding capacity Ø mm		Weight kgs ca.
				Prism standard	Prism version „G“	
WS 95	min. 240 / max. 590	25	1050	26 - 40	45 - 60	8,0
WS 95 K	min. 240 / max. 590	25	720	26 - 40	45 - 60	6,5
WS 95 VSZ	min. 240 / max. 590	25		26 - 40	45 - 60	9,5

Special designs on request.

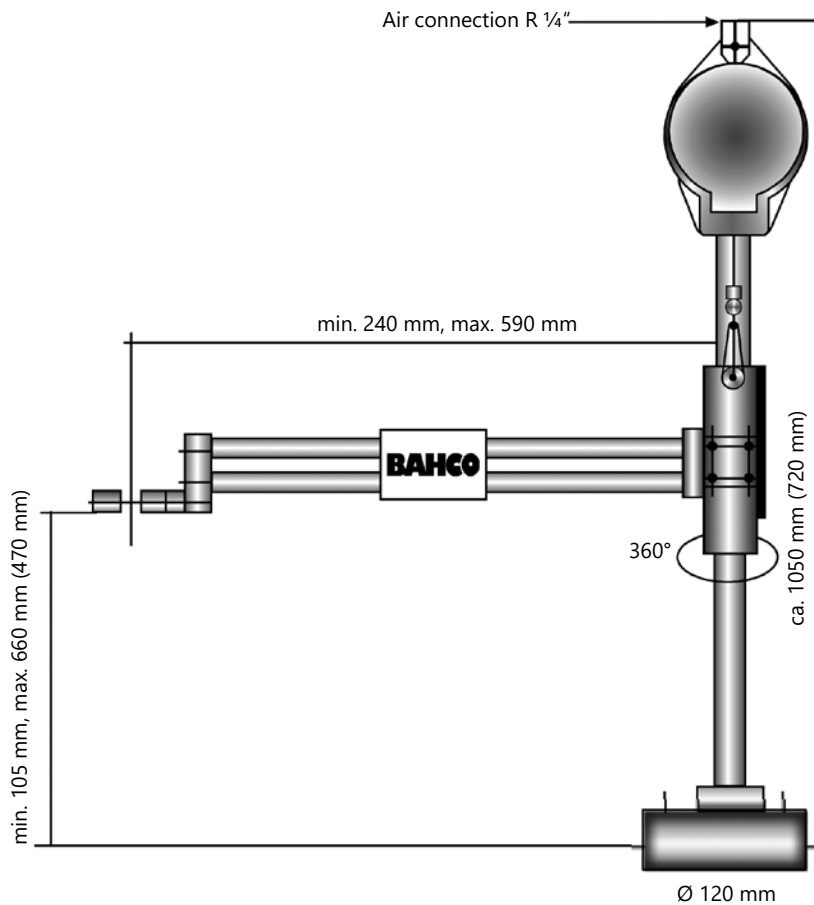

Dimensions in () = Model "K"

**Special version with automatic thrust,
Type: WS 95 VSZ**

- This type performs the vertical movement of the tool arm, pressure air supported by a button.
 - By means of a push cylinder which is actuated by a pilot valve in the handle, the „arm“ moves upwards
- or down wards (keep the down button pressed „arm“ moves down, release the button: „arm“ moves upwards).
- In this version, the spring balancer and the spiral hose is not applicable.

BAHCO
DORTMUND

BAHCO GmbH & Co.KG

Martener Hellweg 60
DE- 44379 Dortmund

Phone

+49 231/91 72 11-0

Fax

+49 231/91 72 11-22

www.bahco.de

info@bahco.de

BAHCO

All information subject to change without further notice.
No responsibility is taken for the correctness of the named specifications.