

700 BAR

**BAHCO**  
DORTMUND



**ELECTRIC MOTOR PUMP  
PME 1S-6VE  
WITH REMOTE CONTROL**

**BAHCO**

This 2-stage, compact motor pump with steel tank and oil cooler is designed to operate single-acting cylinders and cutting tools.

**Features:**

- Operating pressure 700 bar (800 bar on request)
- Electric motor 230 V, 1.5 kW
- 3/3-way solenoid valve with pressure holding function
- Delivery incl. gauge and carrying frame
- Remote control with a 5m long cable, control voltage 24V
- Automatic switching low pressure (LP) / high pressure (HP)
- Externally adjustable pressure relief valve
- For the operation of single-acting cylinders with quick-stop nipple (hose rupture protection), a non-return valve TVP is absolutely necessary for the pump.

# PME ELECTRIC MOTOR PUMP

Technical data								
Type	Electric Motor	Valve typ	Hydraulic pump				Effective oil volume	Weight kg incl. oil
			Working pressure MPa		Flow rate l/min.			
PME-1S-6VE	1,5 kW, AC230V, 50/60Hz single phase	3/3-Wege-Electric-solenoid valve w. pressure holding function	1. stage	2. stage	1. stage	2. stage	Liter	60
			6	70 (80)	6	1.1	13	

## Technical drawing

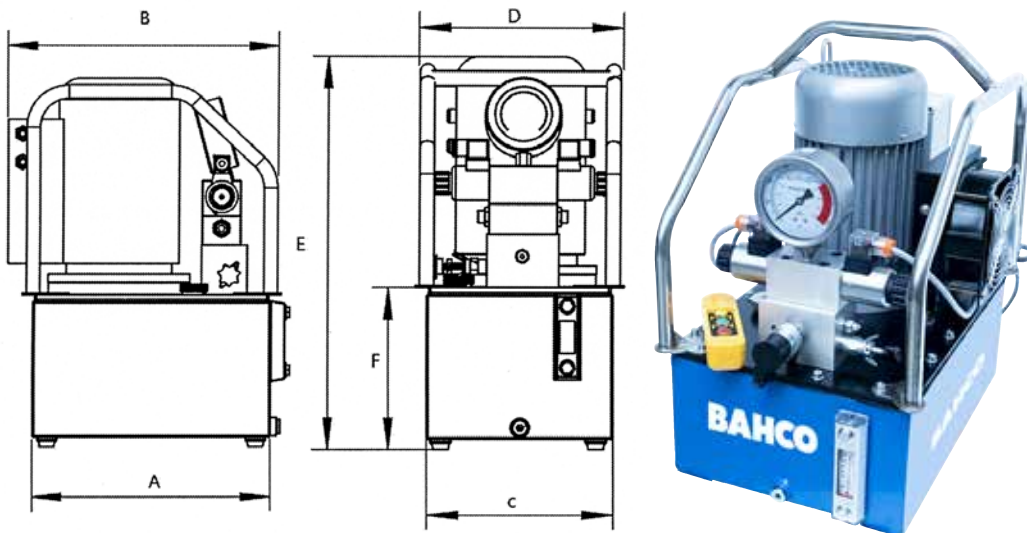

Dimensions						
Model	A mm	B mm	C mm	D mm	E mm	D mm
PME 1S-6VE	430	524	300	336	534	179

**BAHCO**  
DORTMUND

**BAHCO GmbH & Co.KG**

Martener Hellweg 60  
DE- 44379 Dortmund

**Phone**

+49 231/91 72 11-0

**Fax**

+49 231/91 72 11-22

[www.bahco.de](http://www.bahco.de)

[info@bahco.de](mailto:info@bahco.de)

**BAHCO**

All information subject to change without further notice.  
No responsibility is taken for the correctness of the named specifications.