

# 700 BAR

**BAHCO**  
DORTMUND



**ELECTRIC MOTOR PUMP  
PME 1S-6VE  
WITH REMOTE CONTROL**

# BAHCO

## BAHCO GmbH & Co.KG

Martener Hellweg 60

DE- 44379 Dortmund

### Phone

+49 231/91 72 11-0

### Fax

+49 231/91 72 11-22

www.bahco.de

info@bahco.de

This 2-stage, compact motor pump with steel tank and oil cooler is designed to operate single-acting cylinders and cutting tools.

### Features:

- Operating pressure 700 bar (800 bar on request)
- Electric motor 230 V, 1.5 kW
- 3/3-way solenoid valve with pressure holding function
- Delivery incl. gauge and carrying frame

- Remote control with a 5m long cable, control voltage 24V
- Automatic switching low pressure (LP) / high pressure (HP)
- Externally adjustable pressure relief valve
- For the operation of single-acting cylinders with quick-stop nipple (hose rupture protection), a non-return valve TVP is absolutely necessary for the pump.

## Technical data

Type	Electric Motor	Valve typ	Hydraulic pump				Effective oil volume	Weight incl. oil
			Working pressure MPa		Flow rate l/min.			
			1. stage	2. stage	1. stage	2. stage		
PME-1S-6VE	1,5 kW, AC230V, 50/60Hz single phase	3/3-Wege-Electric-solenoid valve w. pressure holding function	6	70 (80)	6	1,1	13	60

## Technical drawing

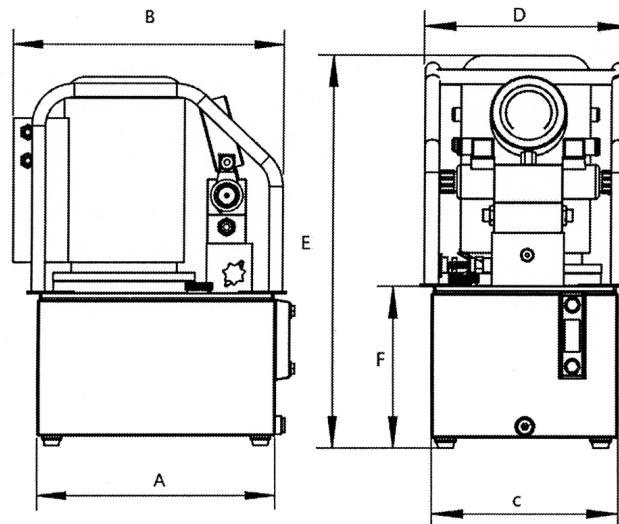

## Dimensions

Type	A	B	C	D	E	D
	mm					
PME 1S-6VE	430	524	300	336	534	179

All information subject to change without further notice.  
No responsibility is taken for the correctness of the named specifications.